

IP Addressing



Network and Host Addressing

Using the IP address of the destination network, a router can deliver a packet to the correct network.

When the packet arrives at a router connected to the destination network, the router uses the IP address to locate the particular computer connected to that network.

Accordingly, every IP address has two parts.

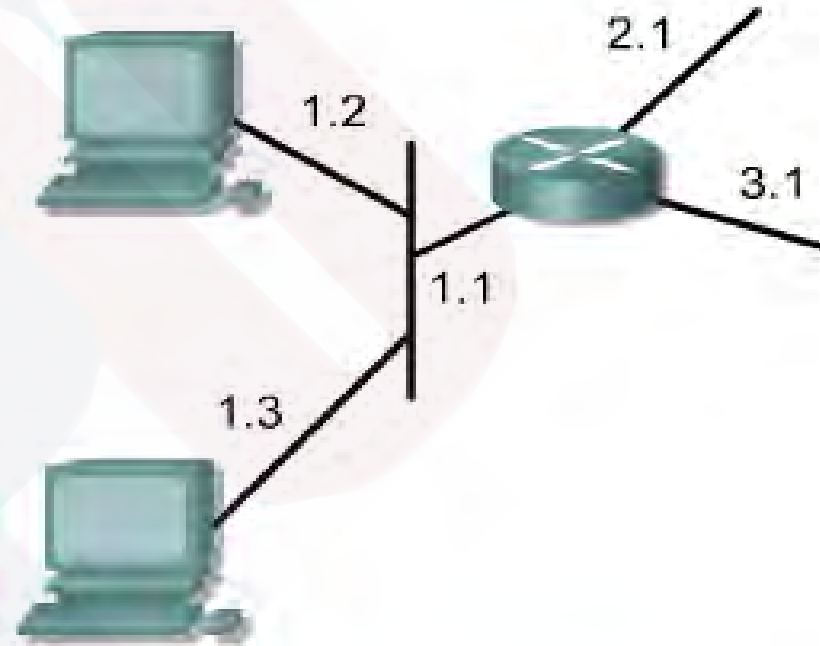

Network	Host
1	1
	2
	3
2	1
3	1

Network Layer Communication Path

A router forwards packets from the originating network to the destination network using the IP protocol. The packets must include an identifier for both the source and destination networks.

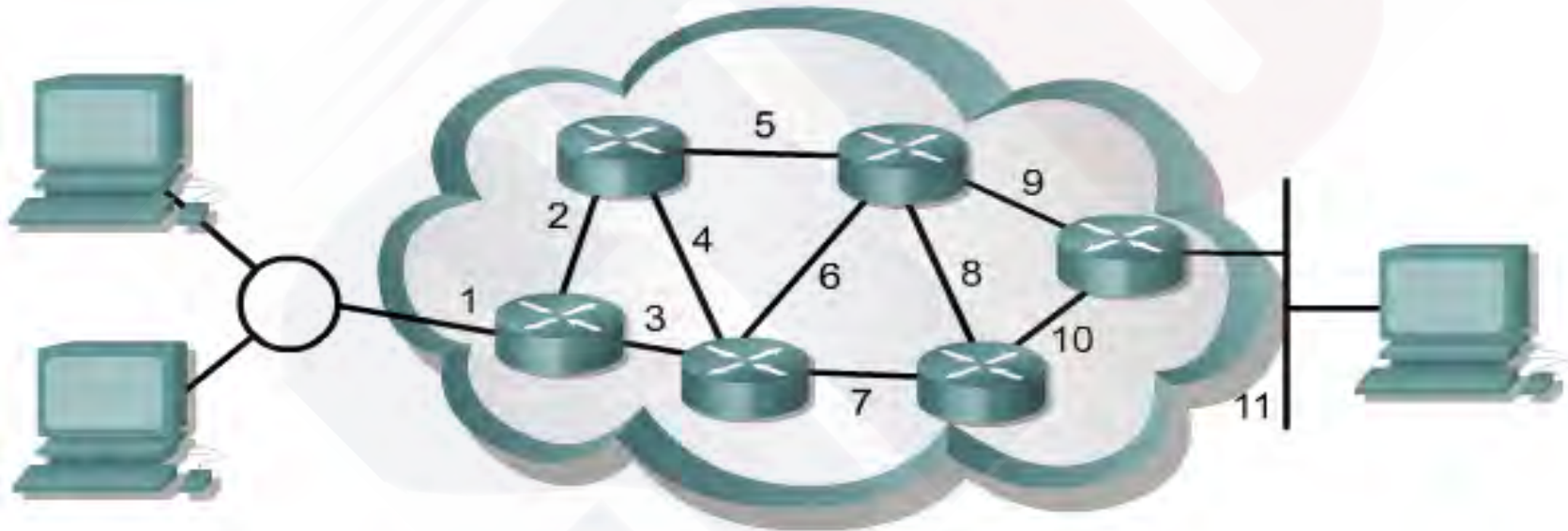

Address represent the path of media connections

Internet Addresses

IP Addressing is a hierarchical structure. An IP address combines two identifiers into one number. This number must be a unique number, because duplicate addresses would make routing impossible. The first part identifies the system's network address. The second part, called the host part, identifies which particular machine it is on the network.

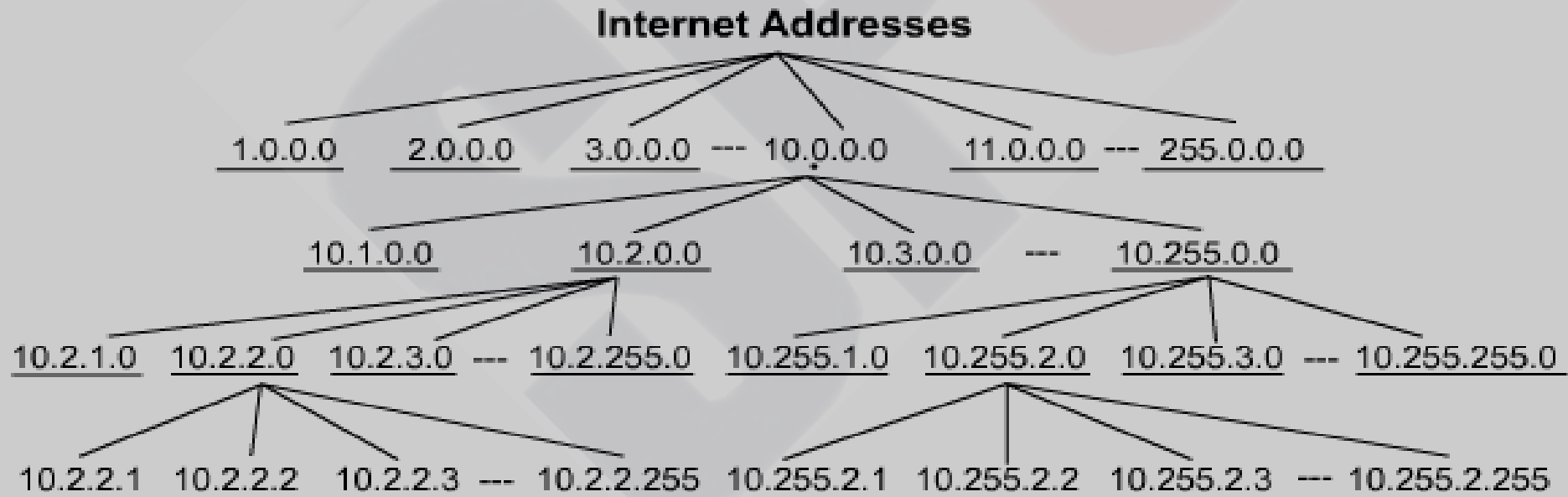

IP Address Classes

IP addresses are divided into classes to define the large, medium, and small networks.

Class A addresses are assigned to larger networks.

Class B addresses are used for medium-sized networks, &

Class C for small networks.

Address Class	Number of Networks	Number of Host per Network
A	126 *	16,777,216
B	16,384	65,535
C	2,097,152	254
D (Multicast)	N/A	N/A

Identifying Address Classes

IP Address Class	High Order Bits	First Octet Address Range	Number of Bits in the Network Address
Class A	0	0 - 127 *	8
Class B	10	128 - 191	16
Class C	110	192 - 223	24
Class D	1110	224 - 239	28

* The 127.x.x.x address range is reserved as a loopback address, used for testing and diagnostic purposes.

Address Class Prefixes

To accommodate different size networks and aid in classifying these networks, IP addresses are divided into groups called classes. This is **classful addressing**.

Class A	Network	Host		
Octet	1	2	3	4

Class B	Network		Host	
Octet	1	2	3	4

Class C	Network			Host
Octet	1	2	3	4

Class D	Host			
Octet	1	2	3	4

Class D addresses are used for multicast groups. There is no need to allocate octets or bits to separate network and host addresses. Class E addresses are reserved for research use only.

Network and Host Division

Each complete 32-bit IP address is broken down into a network part and a host part. A bit or bit sequence at the start of each address determines the class of the address. There are 5 IP address classes.

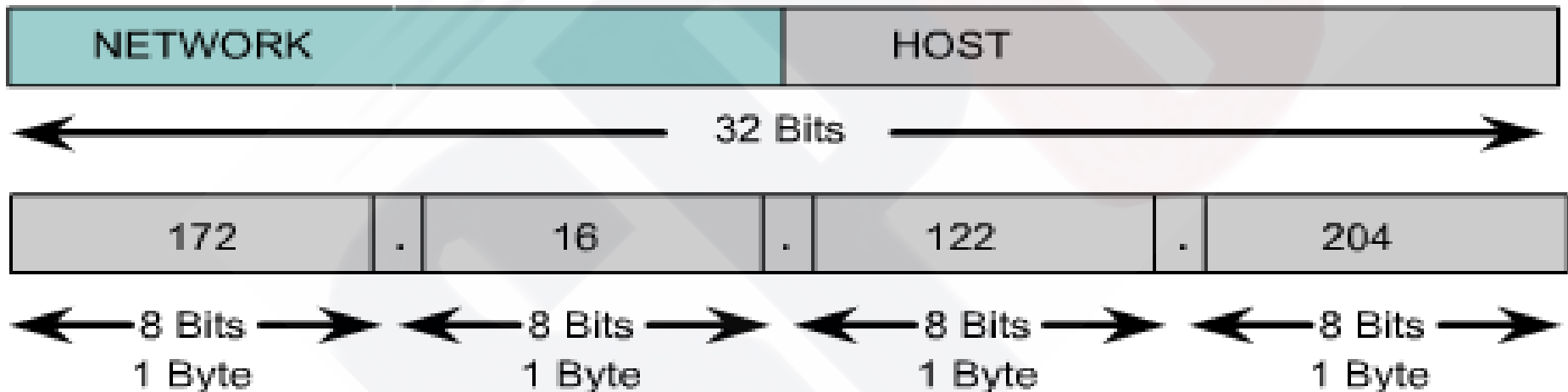

An IP address will always be divided into a network and host portion. In a classful addressing scheme, these divisions take place at the octet boundaries.

Class A Addresses

The Class A address was designed to support extremely large networks, with more than 16 million host addresses available. Class A IP addresses use only the first octet to indicate the network address. The remaining three octets provide for host addresses.

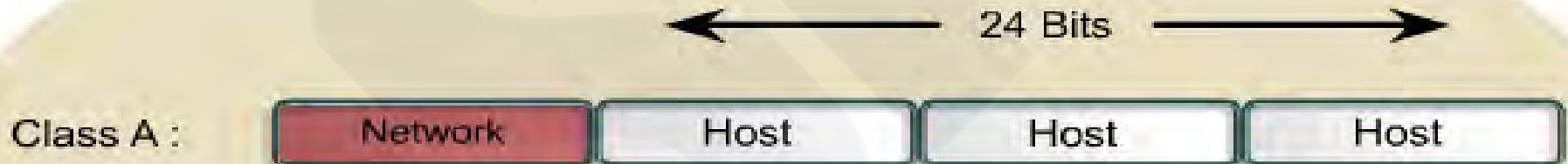

Class B Addresses

The Class B address was designed to support the needs of moderate to large-sized networks. A Class B IP address uses the first two of the four octets to indicate the network address. The other two octets specify host addresses.

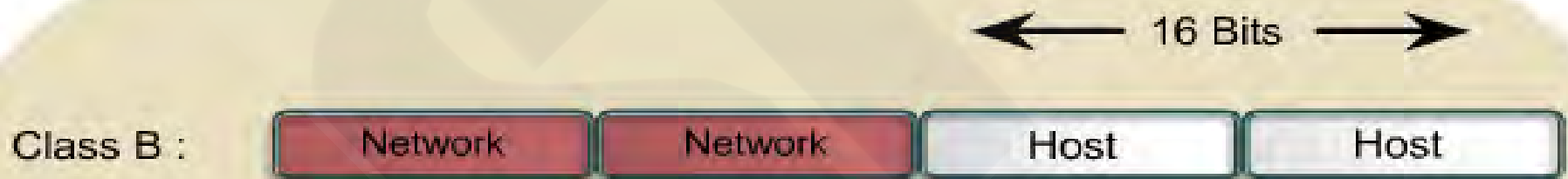

Class C Addresses

The Class C address space is the most commonly used of the original address classes. This address space was intended to support small networks with a maximum of 254 hosts.

Class C :



Class D Addresses

The Class D address class was created to enable multicasting in an IP address. A multicast address is a unique network address that directs packets with that destination address to predefined groups of IP addresses. Therefore, a single station can simultaneously transmit a single stream of data to multiple recipients.

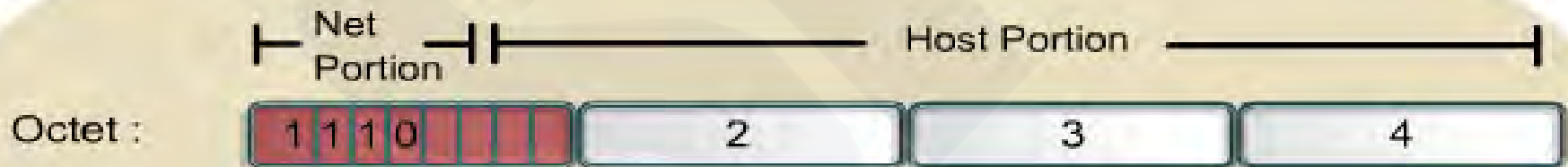

Class E Addresses

A Class E address has been defined. However, the Internet Engineering Task Force (IETF) reserves these addresses for its own research. Therefore, no Class E addresses have been released for use in the Internet.

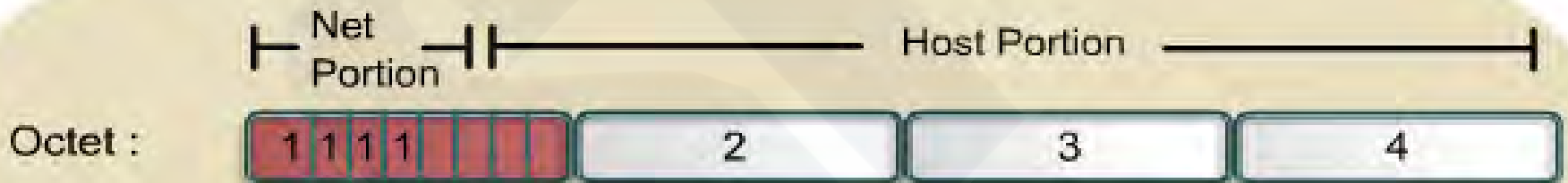

IP Address Ranges

The graphic below shows the IP address range of the first octet both in decimal and binary for each IP address class.

IP address class	IP address range (First Octet Decimal Value)
Class A	1-126 (00000001-01111110) *
Class B	128-191 (10000000-10111111)
Class C	192-223 (11000000-11011111)
Class D	224-239 (11100000-11101111)
Class E	240-255 (11110000-11111111)

Determine the class based on the decimal value of the first octet

* 127 (01111111) is a Class A address reserved for loopback testing and cannot be assigned to a network.

IPv4

As early as 1992, the Internet Engineering Task Force (IETF) identified two specific concerns: Exhaustion of the remaining, unassigned IPv4 network addresses and the increase in the size of Internet routing tables.

Over the past two decades, numerous extensions to IPv4 have been developed. Two of the more important of these are subnet masks and classless interdomain routing (CIDR).

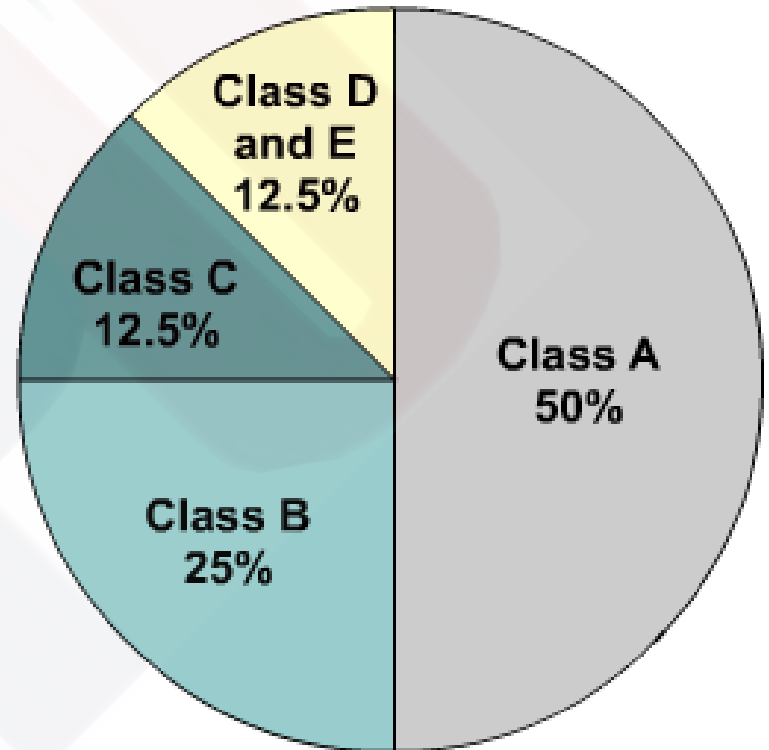

With Class A and B addresses virtually exhausted, Class C addresses (12.5 percent of the total space) are left to assign to new networks.

Finding the Network Address with ANDing

By ANDing the Host address of **192.168.10.2** with **255.255.255.0** (its network mask) we obtain the network address of **192.168.10.0**

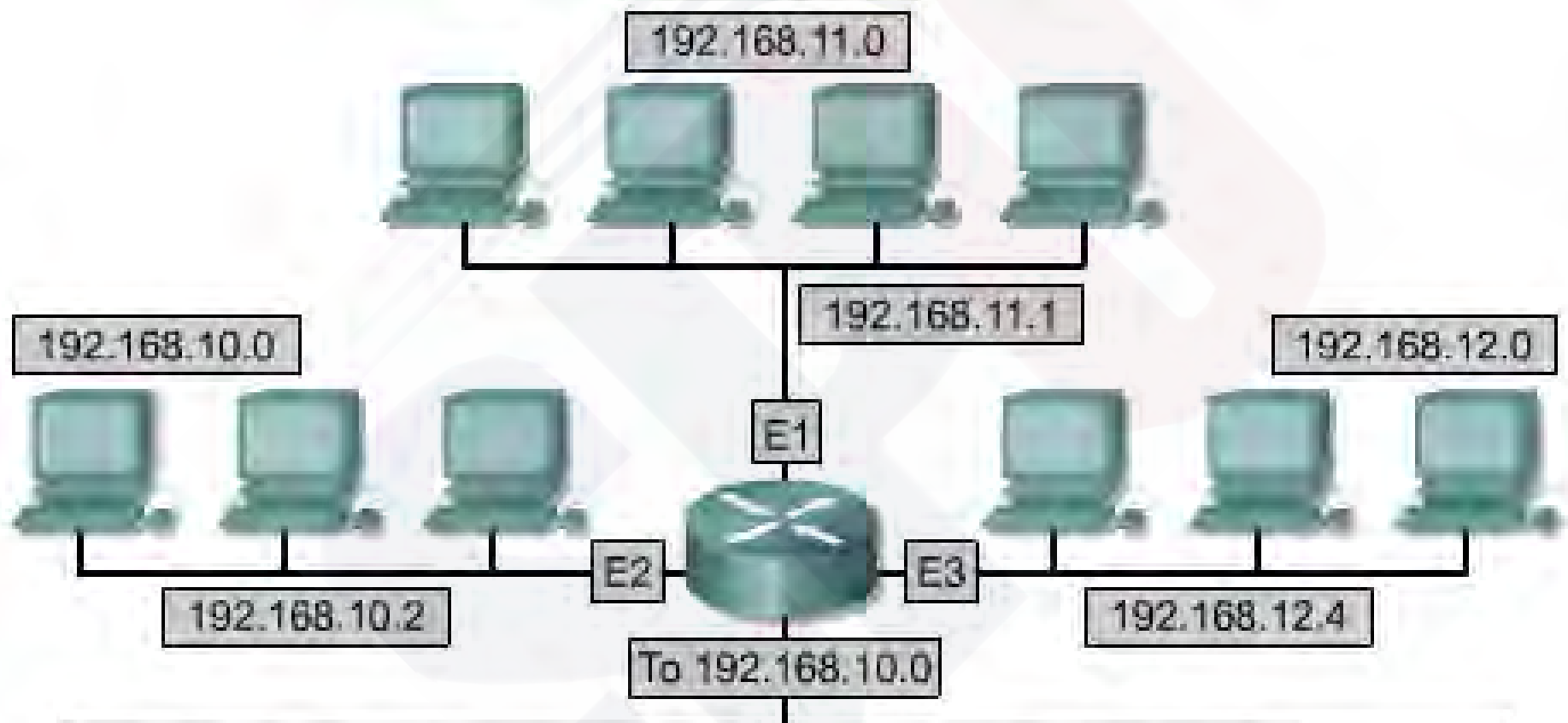

192.168.10.2	11000000	10101000	00001010	00000010
AND			AND	
255.255.255.0	11111111	11111111	11111111	00000000
	<hr/>			
	11000000	10101000	00001010	00000000

Network Address

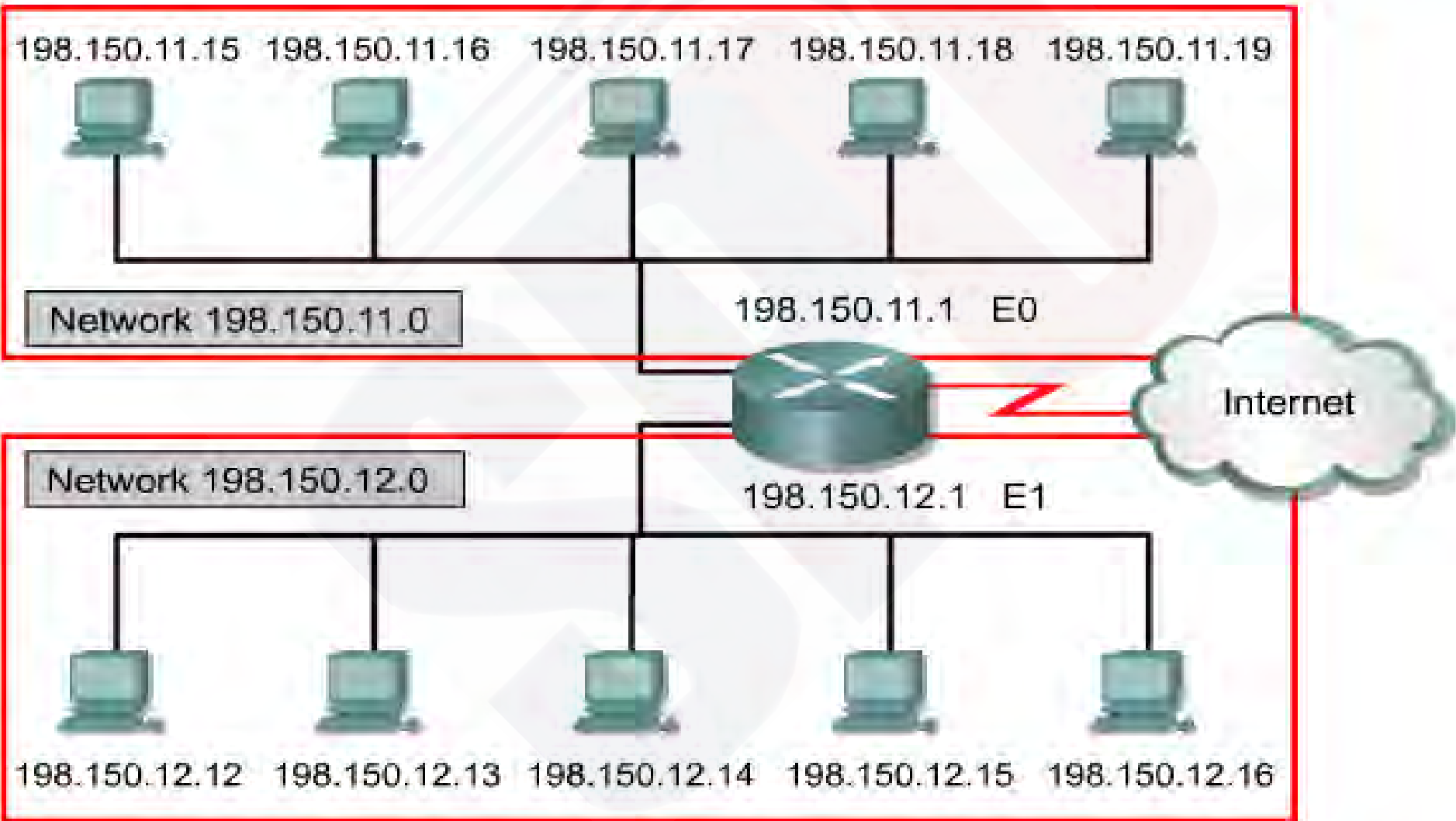

Broadcast Address

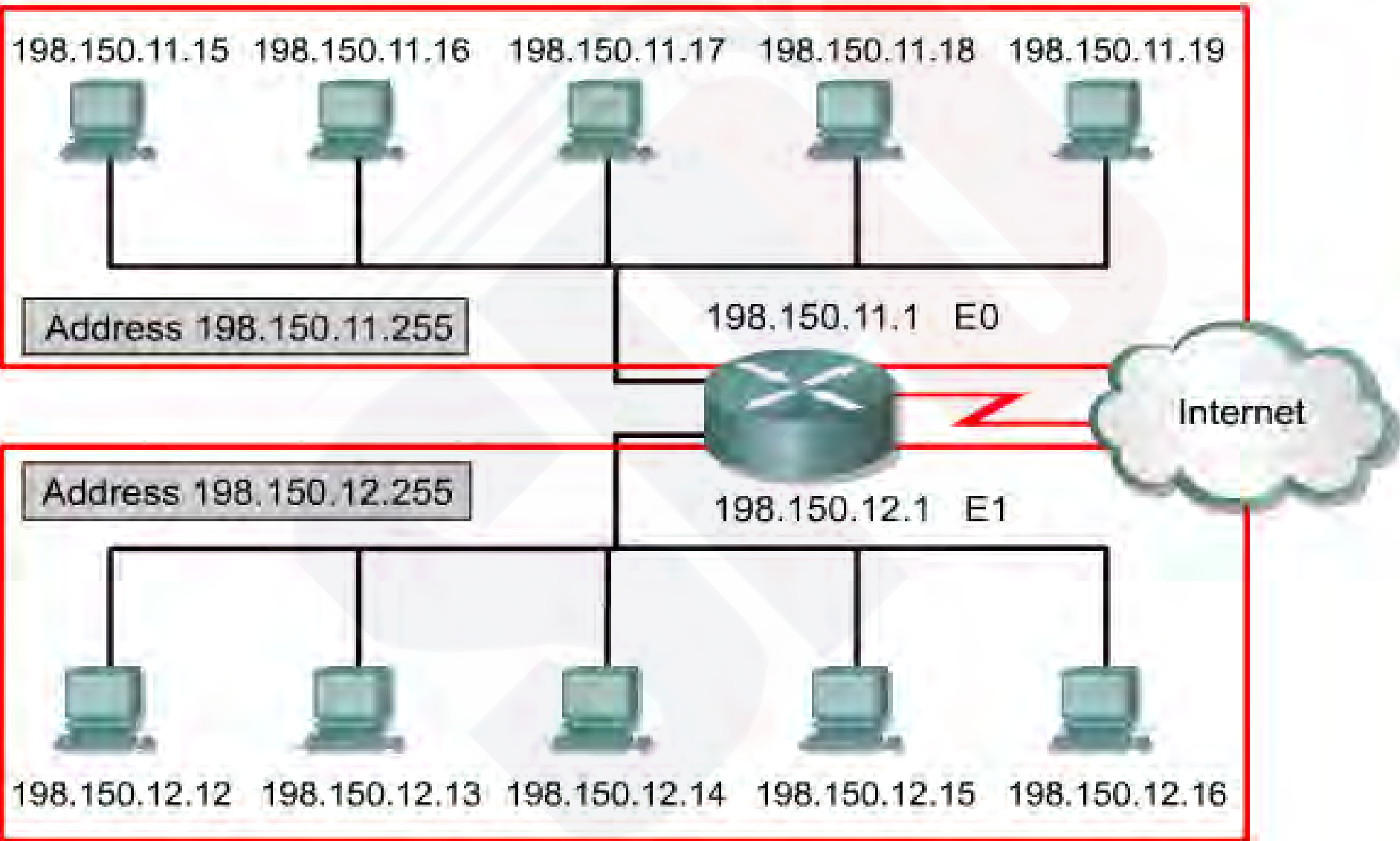

Network/Broadcast Addresses at the Binary Level

An IP address that has binary 0s in all host bit positions is reserved for the network address, which identifies the network. An IP address that has binary 1s in all host bit positions is reserved for the broadcast address, which is used to send data to all hosts on the network. Here are some examples:

<u>Broadcast Address</u>	<u>Network Address</u>	<u>Class</u>
100.255.255.255	100.0.0.0	A
150.75.255.255	150.75.0.0	B
200.100.50.255	200.100.50.0	C

Public IP Addresses

Unique addresses are required for each device on a network.

Originally, an organization known as the Internet Network Information Center (InterNIC) handled this procedure.

InterNIC no longer exists and has been succeeded by the Internet Assigned Numbers Authority (IANA).

No two machines that connect to a public network can have the same IP address because public IP addresses are global and standardized.

All machines connected to the Internet agree to conform to the system.

Public IP addresses must be obtained from an Internet service provider (ISP) or a registry at some expense.

Private IP Addresses

Private IP addresses are another solution to the problem of the impending exhaustion of public IP addresses. As mentioned, public networks require hosts to have unique IP addresses.

However, private networks that are not connected to the Internet may use any host addresses, as long as each host within the private network is unique.

Class	RFC 1918 internal address range
A	10.0.0.0 to 10.255.255.255
B	172.16.0.0 to 172.31.255.255
C	192.168.0.0 to 192.168.255.255

Introduction to Subnetting

Subnetting a network means to use the subnet mask to divide the network and break a large network up into smaller, more efficient and manageable segments, or subnets.

With subnetting, the network is not limited to the default Class A, B, or C network masks and there is more flexibility in the network design.

Subnet addresses include the network portion, plus a subnet field and a host field. The ability to decide how to divide the original host portion into the new subnet and host fields provides addressing flexibility for the network administrator.

The 32-Bit Binary IP Address

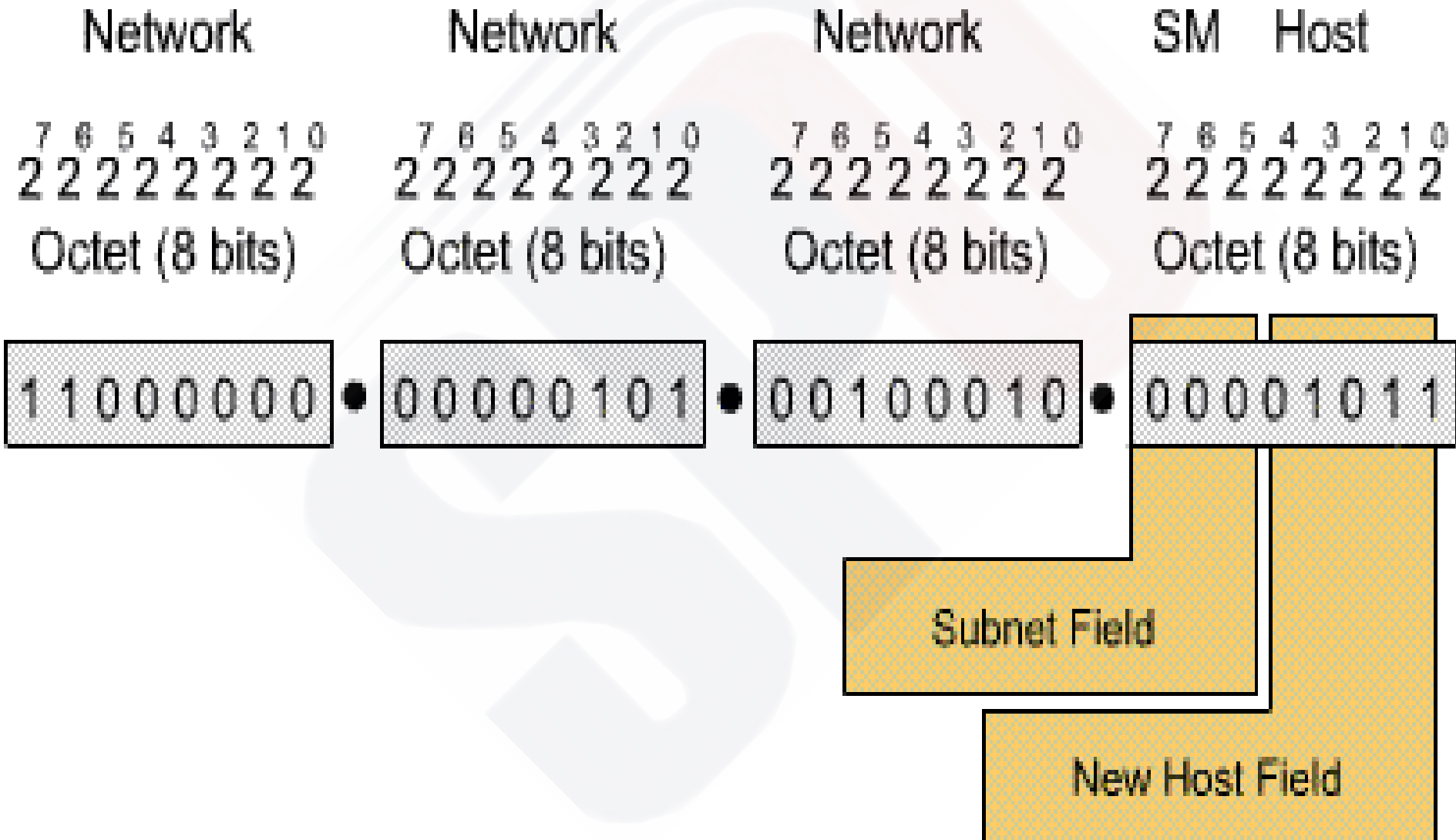

Addressing with Subnetworks

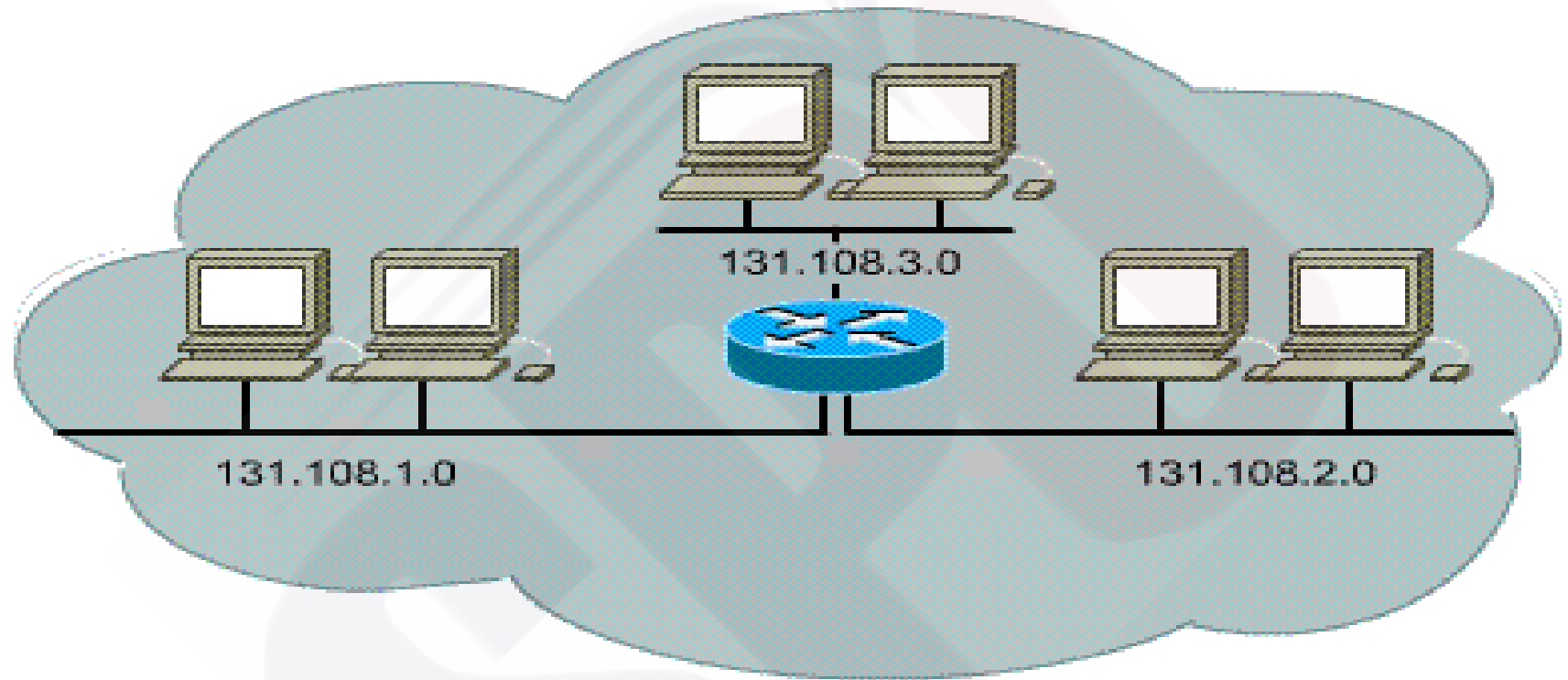

Internally, networks may be divided into smaller networks called sub-networks, or simply sub-nets. By providing a third level of addressing, sub-nets provide extra flexibility for the network administrator. For example, a class "B" network provided by the InterNIC, can be broken up into many sub-networks. In this example, 131.108.1.0, 131.108.2.0, and 131.108.3.0 are all sub-nets within the network 131.108.0.0.

Obtaining an Internet Address

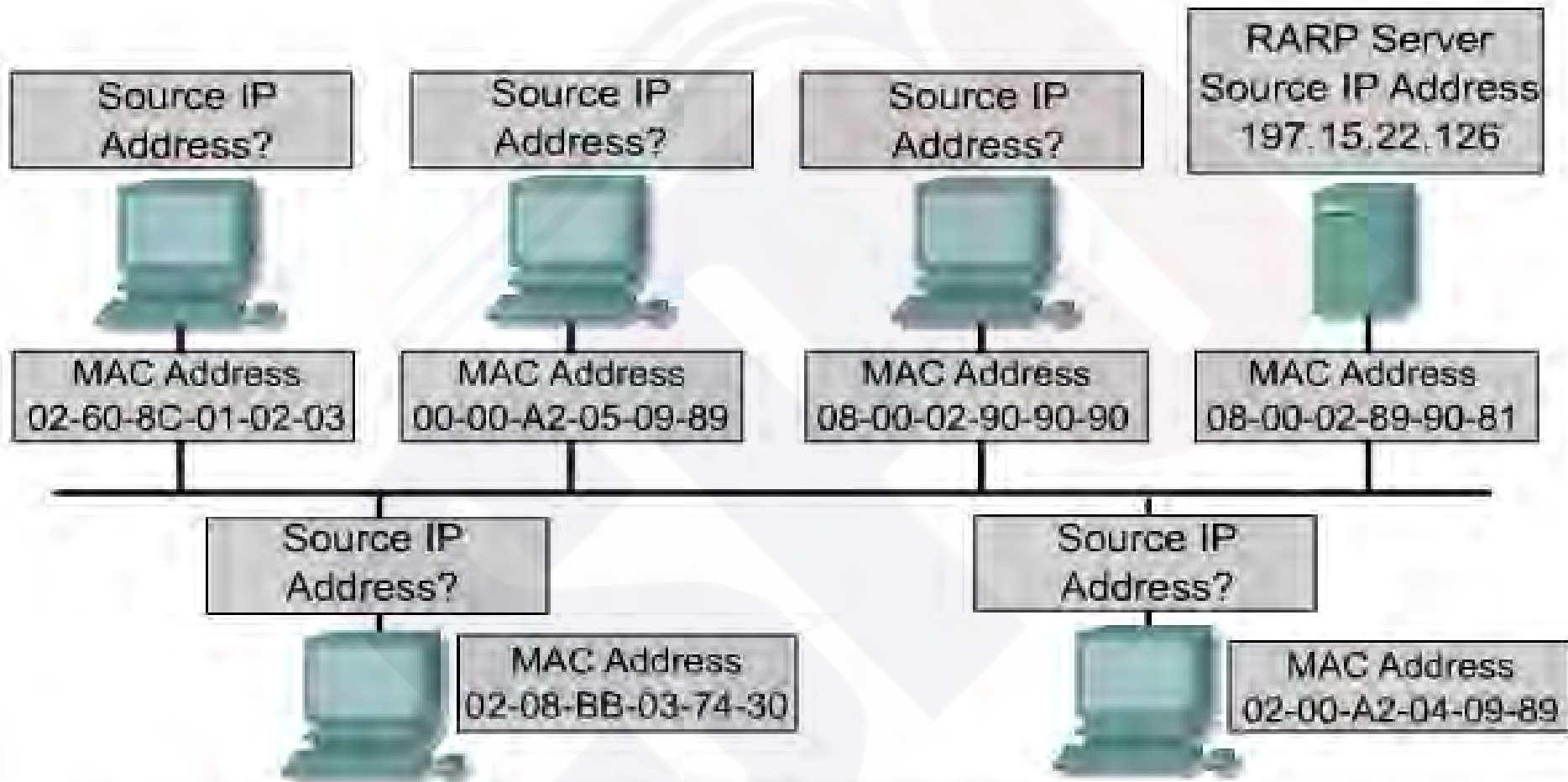

The hosts have a physical address by having a network interface card that allows connection to the physical medium. IP addresses have to be assigned to the host in some method. The two methods of IP address assignment are static or dynamic.

Static Assignment of an IP Address

Static assignment works best on small networks.

The administrator manually assigns and tracks IP addresses for each computer, printer, or server on the intranet.

Network printers, application servers, and routers should be assigned static IP addresses.

